

# DC Immersion

---

Original instructions

Part No 94259



**WARNING!** Read the instruction manual before using the the Dustcontrol Immersion separator.

Dustcontrol reserves the right to change specifications without notice and is under no obligation to alter previously delivered products. Dustcontrol is not responsible for errors or omissions in this user instruction.

**Manufactured by:**

Dustcontrol AB  
Box 3088, Kumla Gårdsväg 14  
SE-145 03 Norsborg  
Tel: + 46 8 531 940 00  
Fax: + 46 8 531 703 05  
support@dustcontrol.se  
www.dustcontrol.com

**Sold by:**

# Contents

Safety Considerations _____	4-5	Wear parts _____	12
Purpose of use _____	5	Warranty _____	12
Technical Data _____	6-7	Limitation of Liability _____	13
Installation _____	8-9	Trouble shooting _____	13
Service _____	10-12	Spare parts _____	14
Accessories _____	12	Dustcontrol Worldwide _____	15

# Safety Considerations

Read the following safety instructions before starting the Dustcontrol Immersion separation unit. Save the instruction.

## 1. Work area

- **WARNING!** Use of water prohibited, Immersion fluid must not be reactive to the metals/materials being collected.

- **WARNING!** This unit may only be used indoors, in a well-ventilated area.

- **WARNING!** The customer/user is fully responsible that the material and the mixture of liquid and material will not cause any damage. This pre-separator is a component in a source extraction system which must be approved by an expert in the field and follow laws and regulations and applicable standards.

## 2. Use

- **WARNING!** When using the product, apply basic safety precautions to reduce the risk of fire, electric shock or injury.

- **WARNING!** The user should be sufficiently trained on the use of this device.

- **WARNING!** Disposal arrangements for the sludge, liquid and the collected chip shall be planned arranged before start up and follow all applicable federal, state and local regulations.

- **WARNING!** This unit shall in operation, be filled with the appropriate liquid up to the liquid level indicator arrow at the level window. Check the fluid level regularly.

- **WARNING!** Collected dust/chip may not exceed the rate according to the technical data. How often the sieve basket needs to be emptied depends on the character of the material intake; i.e. velocity, amount etc. The unit must be monitored to not exceed the maximum limit of material collected.

- **WARNING!** This unit is designed for separation of fine materials. It may also be used for neutralization of hot or glowing media. It cannot be used for both materials simultaneously.

- **CAUTION!** This device is not intended for use by minors or persons with reduced physical, sensory or mental capabilities or lack of experience and knowledge, unless supervised or instructed concerning use of the device by a person responsible for their safety.

- **CAUTION!** Clean the unit immediately after each use and at intervals as the risk assessment stated. See chapter Maintenance and Cleaning for instructions.

- **CAUTION!** To prevent gas accumulations inside the container. Make sure that the vent flap on the unit's top is never covered.

- **CAUTION!** Check the filters for material build-up. Clean filters and the unit thoroughly on a regular basis and according to the risk assessment.

- **CAUTION!** Monitor the unit to make sure it is at all time running according to the specification and risk assessment.

- **CAUTION!** ! Clean the sight glass regularly to ensure good visibility into the unit.

## 3. Physical injury

Never let the suction encounter parts of the body. The strong suction effect can hurt the blood-vessels in the skin. The unit should only be serviced by qualified personnel. Faults may cause injury.

## 4. Care

- **WARNING!** Before cleaning and maintenance, disconnect the pre-separator from the suction source. Make sure that equipotential bonding between the worker and the pre-separator is established.

Keep the pre-separator/unit clean and ensure that the hose is intact and that all seals are tight.

After each use, make sure that the hose and separator is clean from material.

Use only accessories and replacement parts that are recommended in this user instruction.

# Safety Considerations

## 5. Control

Always check that the separator/unit and its components is undamaged before use. Damage must be repaired by an authorized service workshop approved by Dustcontrol.

## 6. Transport

At transportation where vehicles or other means are needed, the unit must be emptied and cleaned.

# Purpose of use

The Dustcontrol Immersion separation unit is designed to collect combustible metals transported in an airflow by completely immersing the intake air into a liquid.

By completely immersing all the intake air in the neutralizing liquid, ignition sources and solids are collected and neutralized at an early stage.

The solids transported by the air flow could be composed of different origin and therefore it is necessary to make an analysis to determine the right fluid to avoid hazardous situations but also for optimization of the unit.

The unit must be connected to a vacuum system to provide sufficient flow with correctly dimensioned hoses to avoid settling of particles in the hose. The vacuum system must have a control system with necessary functions for safe operating and controlling the whole system.

The Dustcontrol Immersion separation unit is designed to be used together with the collection basket for easy emptying and cleaning of the device.

The immersing neutralization liquid, a light mineral oil must be chosen in consideration to the deposited material and applicable standards. Some combinations may emit combustible gases or other hazardous gases.

Before use, a risk assessment covering all processes during the work and service cycles should be established by an expert in the field. Clear instructions must be attached to the unit.



# Technical Data

Dimensions (HxWxD)	1480x620x838 mm/58.3x24.4x33.0 in
Weight	40 kg/88 lb
Inlet	Ø 59 mm/2.32 in
Outlet	Ø 76 mm/2.99 in
Air flow min/max	140 m <sup>3</sup> /h/250 m <sup>3</sup> /h/82 cfm/147 cfm
Air flow temperature	5-40° C
Surrounding temperature	5-30° C
Neutralizing liquid volume	8-20 l/4.7-5.3 gal
Neutralizing liquid*	Use of water prohibited, Immersion fluids must not be reactive to the metals/materials being collected.
Chip collection capacity	1l or maximum 5% of the liquid level according to the NFPA standard.
Fine filter	Oil and water resistant conductive
Spigot for ventilation	Ø 125 mm/4.92 in
MIE	>3mJ

# Technical Data

## System Overview

This is a schematic overview of the immersion separation system.

## Components

- A Suction inlet
- B Immersion separator
- C Connection inlet
- D Sieve basket
- E Fluid catching filter
- F Demister filter
- G Fine filter
- H Locks
- I Lid
- J Gas vent
- K Trolley
- L Grounding cable
- M Drain valve
- N Water level indicator and window

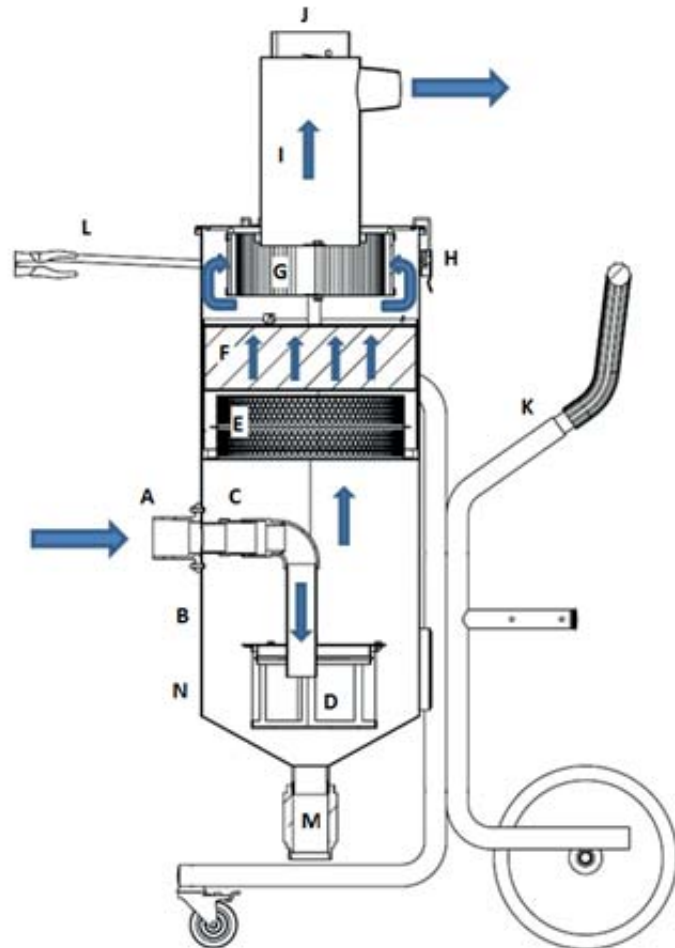

Fig 1: Cross section and air flow direction of the unit.

# Installation

## Start using your device

Before every time of use, the device should be inspected visually to ensure that it is complete and in good condition. Check cautions and warnings above and fulfil the requirements in the risk assessment. Follow the local fire marshal's safety instructions and make sure that all steps from start to cleaning and disposal of contained material is prepared before start using the unit.

Follow the steps below before use.

## Operation

1. Disconnect or turn the suction source off.

**NOTE!** For operation instructions on the suction source, see the manual of suction source.

2. Disconnect the device from the suction source. Grounding cable and hose between the suction source and the unit should be disconnected.
3. Loosen the eccentric latch and remove the lid. Place it on a clean and well protected flat surface.
4. When using a fine filter, make sure the filter is securely mounted in the lid.
5. Lift the demister-cassette and place it on a clean and well protected flat surface.



*Removing the demister cassette.*

6. Check that the collecting sieve basket is securely fastened and in good condition.



*Sieve basket*

7. Make sure the device and its accessories are clean and dry before use.
8. Fill the unit with liquid up to the liquid level indicator at the window.

**NOTE!** The user has the responsibility to select suitable liquid to neutralize the material collected.

9. Check sealing at demister rim inside the unit.
10. Place the demister filter back.
11. Check the lid sealing.
12. Put the lid on top and secure the eccentric latches.
13. Connect the outlet to the suction source.
14. Attach grounding cable to the suction unit or other grounding area and check the resistance.
15. Check earth continuity before start.
16. Turn the suction source on. Consult the manual of the suction source.
17. Make sure that the air flow specification at all time is fulfilled.



# Installation

## Running mode

Supervise the unit at all time to keep it running inside specification.

1. Level of the immersion fluid.

2. Air flow at specified level.
3. Keep hold of the amount of material contained in the sieve basket. Over loading may cause additional risks.

## Immersion unit during stops or in halted mode

When the Immersion unit is stopped permanently or is halted consult the local/site risk assessment for detailed instruction. Some fluid and solid combinations might create explosive or harmful gases.

When using some neutralizing liquids, the metal and the liquid combination could produce hydrogen which is easily ignited, safety precautions must be implemented. When the unit is out of operation or if the flow through the device fails, a fan must be connected to the spigot on top of the lid to extract the explosive gas. Airflow through the

unit must at **all** time be maintained. If necessary, all contaminated parts in the system should be emptied and cleaned.

If the system is stopped then the hoses must be disassembled and flow through the spigot ensured to extract harmful or explosive gases.



*Spigot on the lid to attach fan during break.*

# Service

## Maintenance and cleaning

Follow the maintenance and cleaning procedures described below in order to keep the unit in good condition.

If the airflow reaches minimum air flow value, the filter must be cleaned and the collecting bin should be emptied.

Check for air leakage.

If airflow is not reaching risk assessment minimum flow after implementation of the suggested activities, the unit should be checked by a service workshop.

Recommended minimum velocity must be maintained in the hose to transport the material and avoid settling of solids.

**NOTE!** Clean and empty the unit in an appropriate way and at an approved area dispose the used neutralizing liquid and the collected material appropriately.

## Grounding of unit

To prevent explosions and static build up, the unit always needs to be grounded.

The unit should be checked periodically, to ensure continuity in ground. All parts of the unit, including hose and wheels need to be checked in relation to each other. The parts should always measure in at less than 1 mega ohm (<1 M $\Omega$ ) to ground.

## Emptying the neutralizing liquid

1. Disconnect the device from the suction source.
2. Move the unit to an area where discharge is appropriate.
3. Empty the tank by turning the handle to open the valve.
4. Dispose of waste appropriately.

# Service

## Cleaning the unit

1. First, empty the neutralizing liquid according to the instructions described above.
2. Loosen the eccentric latches.
3. Remove the lid and place it on a flat surface.
4. Grip the handle and place the demister filter on a well-protected surface.



*Removing the demister cassette.*

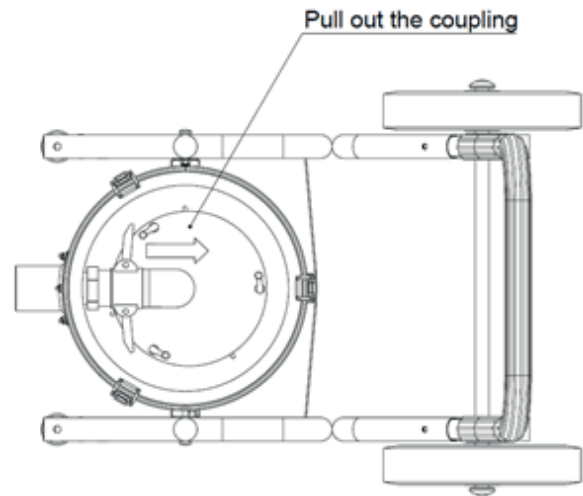

*Release the arms of the quick coupling and pull the coupling back, away from the inlet.*

5. Remove the fluid catching filter. Loosen screw.

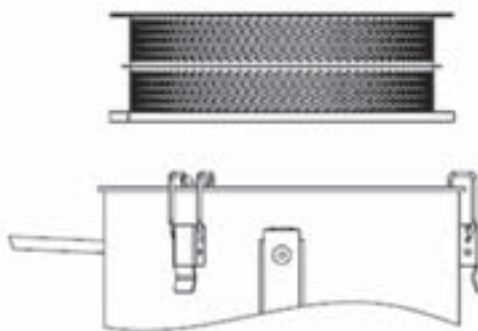

*Remove the fluid catching filter.*

6. Loosen the quick coupling and extract the sieve basket together with the pipe fitting.
7. To open and clean the sieve basket, loosen screws and twist it counter clockwise. Empty the basket from the collected material.

8. Clean the container, filters and the sieve basket.
9. When the container is clean and dry, close the valve and reassemble the unit.

## Replacing or cleaning the the demister

Replace the demister when cleaning does not ease pressure drop significantly.

After using the demister filter for some time particles will clog the filter. This will increase the pressure drop over the filter which can be resolved by maintenance of the filter. Maintenance of demister filter is recommended to perform during longer stops. What cleaning frequency is needed depends of the character of the material collection, what material collected and liquid used.

Clean the demister filter with water.

1. Disconnect the immersion separator from the suction source.
2. Loosen the eccentric latches and remove the lid and place it on a flat surface.
3. Grip the handle and lift the demister filter on a well-protected surface.
4. Open the demister filter by loosening the wing nuts and replace or clean the demister. Deposit the demister appropriately.
5. Assemble the filter package with lid and wing nuts and attach the lid with eccentric latches.

**NOTE!** Always use original filters.

# Service

## Replacement of fine filter

When fine filter is used, replacing the filter should be done when air flow is lower than minimum air flow specification. Filter conductivity and fluids at secondary side must be checked on daily basis.

1. Disconnect the device from the suction source.
2. Loosen the eccentric latches.
3. Remove the lid and place it on a flat surface.

4. Loosen the nuts under the filter and then replace the filter. Check the 2 sealing's between filter and bolts. Replace if they are damaged.
5. Deposit the filter appropriately.

**NOTE!** Always use original filters.

Repair and other service should be performed by an authorized service workshop approved by Dustcontrol.

# Accessories

Description	Part No
Hose set ESD	44321

# Wear parts

Description	Part No
Sealing lid	44310
Sealing demister rim	44340
Fine filter Polyester	44108
Demister	44098

# Warranty

The warranty period is two years and covers manufacturing faults. The warranty is valid provided that the machine is used normally and gets required maintenance. Normal wear is not considered as manufacturing faults. Repairs should be made by Dustcontrol or other company authorized by Dustcontrol. Otherwise the warranty is invalid.

# Limitation of liability

Dustcontrols responsibility and obligations regarding the goods and related thereto should in no event exceed the purchase price of the goods.

Dustcontrol shall not be liable to buyer for any special incidental, indirect, or punitive damages for any reason whatsoever, including, but without limitation damages in the form of (a) loss of profits,

revenues, or anticipated savings resulting from the failure of the equipment to meet specifications or warranties (b) damages suffered by byer as a result of loss of production facilities or equipment (c) cost of replacement equipment (d) damages suffered by customers of the byer (e) any fines or penalties assessed for failure to comply with any law or government regulations.

# Trouble Shooting

Problem	Cause	Solution
Fluid leakage from container.	Valve is not installed appropriately.	Remove the valve. Use thread sealant and then reattach the valve.
	Liquid level window.	Tighten the screws. If it is still leaking, replace the gasket.
Fluid at secondary side of the filter.	Leakage through the filter or bolts.	Change filter or sealing at the bolts.
Cannot drain the fluid.	Ball valve clogged.	Dissolve the clog and check sieve basket thoroughly for leakage.
The flow is low.	Suction source at wrong settings.	Adjust suction source.
	The hose is damaged.	Replace the hose.
	Fine filter is clogged fig1 G.	Clean the filters according to filter cleaning procedures.
	Demister filter is clogged fig1 E.	Clean the filters according to filter cleaning procedures.
	Sieve basket is full fig1 D.	Empty the sieve basket.
Fluid level low.	Leakage of air.	When the unit is running. Check if air is leaking in from any opening.
	High air flow.	Check suction source
	Too long intervals between level controls.	Check liquid level more often.
Others	Leakage.	Check unit for leakages.
	High level of oil and immersed material at filter or demister top.	Check sealing at the demister rim.

ENGLISH

## Spare Parts

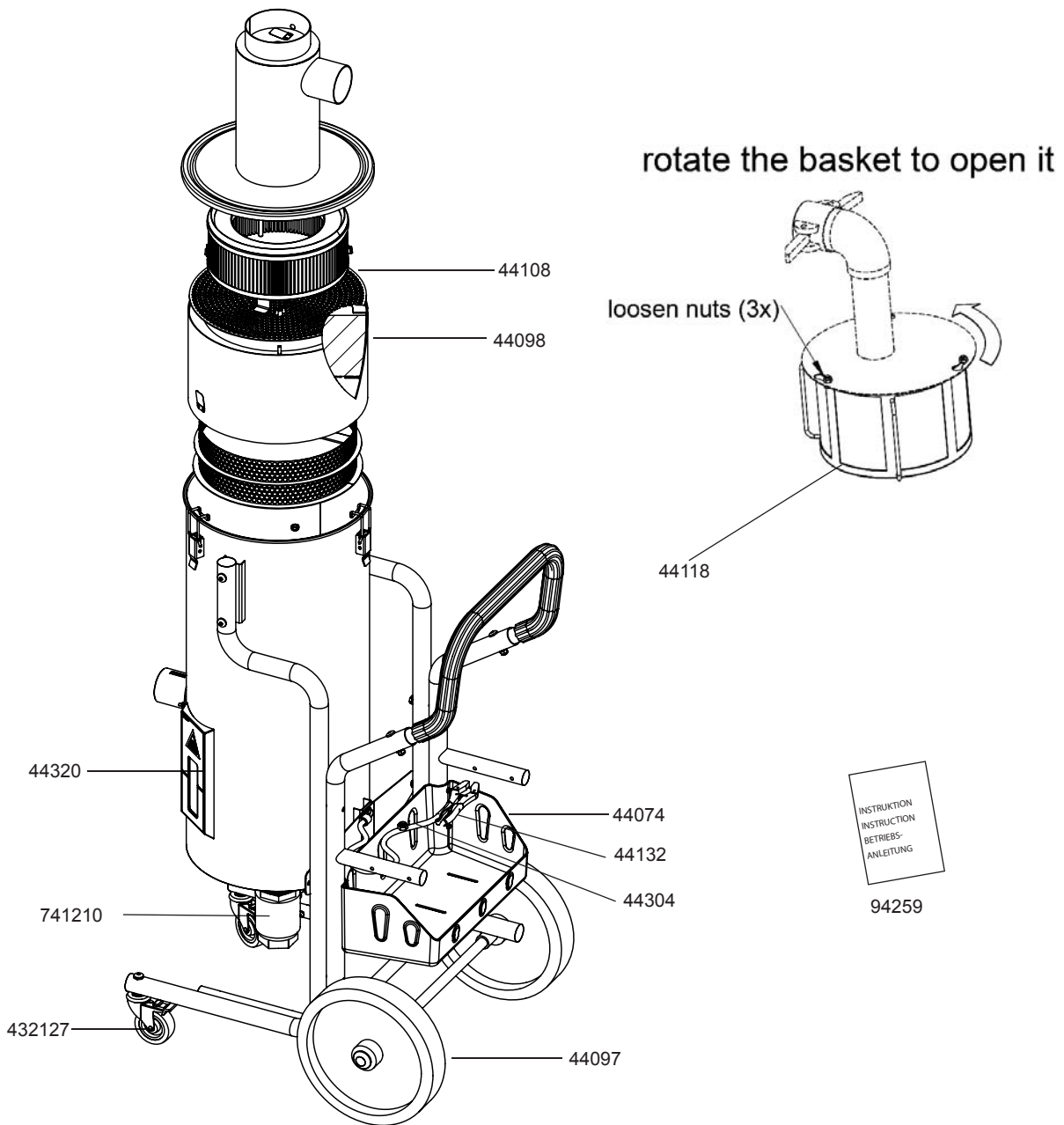

Part No	Description
40497	Wheel, D = 300
432127	Caster, H = 100 Lock
44074	Basket
44098	Wiremesh demister
44108	Fine filter

Part No	Description
44118	Basket
44132	Grounding clamp
44304	Ground cable
44320	Glass set

Part No	Description
741210	Tap G50
94259	Original instructions DC Immersion Separation

*English*

# DUSTCONTROL WORLDWIDE

## **Dustcontrol AB**

Box 3088  
Kumla Gårdsväg 14  
SE-145 03 Norsborg  
Tel: +46 8 531 940 00  
Fax: +46 8 531 703 05  
support@dustcontrol.se  
www.dustcontrol.com

## **AT**

**Dustcontrol Ges.m.b.H.**  
Gradnerstrasse 120-124  
AT-8054 Graz  
Tel: +43 316 428 081  
info@dustcontrol.at  
www.dustcontrol.at

## **AU**

**Archquip - All Preparation Equipment**  
130 Lytton Rd  
AU-4171 Bulimba QLD  
Tel: +61 7 3217 9877  
www.allpreparationequipment.com.au

## **BENELUX**

**Dustsolutions B.V.**  
Eiffelstraat 44  
NL-8013 RT Zwolle  
Tel: +31(0)38-2020154  
sales@dustsolutions.nl  
www.dustsolutions.nl

## **BG**

**Metaltech14 Ltd**  
7 Parva str  
BG-4207 Kadievo  
Tel: +359 888 255 102,  
+359 889 999 593  
metaltex14@abv.bg  
www.dustcontrolbg.com

## **CA**

**Dustcontrol Canada Inc.**  
664 Welham Road  
CA-Barrie, Ontario L4N 9A1  
Tel: +1 877 844 8784  
info@dustcontrol.ca  
www.dustcontrol.ca

## **CH**

**Rosset Technik  
Maschinen Werkzeuge AG**  
Ebersmoos  
CH-6204 Sempach-Stadt  
Tel: +41 41 462 50 70  
info@rosset-technik.ch  
www.rosset-technik.ch

## **CN**

**Suzhou DustCollect Filtration Technology Co., Ltd.**  
Room 218, Building B, No.1368,  
Wuzhong Avenue/ District  
CN-Suzhou City,  
Jiangsu Province  
Tel: +86 180 6800 0359  
sale@dustcollect.cn  
www.dustcollect.cn

## **DE**

**Dustcontrol GmbH**  
Siedlerstraße 2  
DE-71126 Gäufelden-  
Nebringen  
Tel: +49 70 32-97 56 0  
info@dustcontrol.de  
www.dustcontrol.de

## **DK**

**Erenfred Pedersen A/S  
- Construction**  
Rebslagervej 7  
DK-9000 Aalborg  
Tel: +45 98 13 77 22  
info@ep.dk  
www.ep.dk

## **Dansk Procesventilation ApS**

**- Industry**  
Vangeleddet 73  
DK-2670 Greve  
Tel: +45 61 270 870  
info@dansk-procesventilation.dk  
www.dansk-procesventilation.dk

## **EE**

**G-Color Baltic OÜ**  
Ülase 13  
EE-10613 Tallinn  
Tel: +372 682 5919  
sales@g-color.ee  
www.g-color.ee

## **ES**

**Barin, s.a.**  
C/ Cañamarejo, Nº 1  
Poligono Industrial  
Rio de Janeiro  
ES-28110 Algete - Madrid  
Tel: +34 91 6281428  
info@barin.es  
www.barin.es

## **FI**

**Dustcontrol FIN OY**  
Valuraudankuja 6  
FI-00700 Helsinki  
Tel: +358 9-682 4330  
dc@dustcontrol.fi  
www.dustcontrol.fi

## **FR**

**SMH Equipements-Construction**  
Lieu Dit « La Fontaine »  
FR-28630 Berchères Les Pierres  
Tel: +33 (0)2 37 26 00 25  
info@abequipements.com  
www.smhequipements.com

## **Dustcontrol AB France- Industry**

Box 3088  
Kumla Gårdsväg 14  
SE-145 03 Norsborg  
Tel: +46 8 53194016  
hk@dustcontrol.se  
www.dustcontrol.com

## **HU**

**Vandras Kft**  
Kossuth L. u. 65 III.29  
HU-1211 Budapest  
Tel: +36-1-427-0322  
Mobile: +36-20-9310-349  
vandras@t-online.hu  
www.vandras.hu

## **IN**

**Advance Ventilation Pvt. Limited**  
8<sup>th</sup> Floor, NDM-2, Building  
D-1,2,&3, Netaji Subhash Place  
IN-Pitampura, New Delhi-110034  
Tel: +91 47243296-298  
sales@advanceventilation.com  
www.advanceventilation.com

## **IR**

**BioMedoc International Group**  
Rutherford House, Pencroft way,  
Manchester Science Park,  
UK - Manchester, M15 6SZ  
Tel: +44 161 820 8441  
info@biomedoc.com  
www.biomedoc.com

## **IT**

**Airum srl**  
via Maestri del Lavoro 18  
Roveri-2  
IT - 40138 Bologna  
Tel: +39 (0)516 025 072  
info@airum.com  
www.airum.com

## **KR**

**E. S. H Engineering Co.**  
671-267 Sungsu1ga 1dong  
Sungdonggu (P.O)133-112  
KR-Seoul Korea  
Tel: +82 (0)2 466 7966  
k.u.lee@hanmail.net  
www.esheng.co.kr

## **LT**

**UAB Hidromega**  
Mainų g. 23  
LT - 94101 Klaipėda  
Tel: +370 677 10254  
info@hidromega.lt  
www.hidromega.lt

## **LV**

**SIA Reaktivs**  
Rigas iela 113,  
Salapils, LV-2169  
Tel: +371 20282200  
reaktivs@reaktivs.lv  
www.reaktivs.lv

## **MY, ID**

**Blöndal Städa (M) Sdn. Bhd.**  
Blöndal Building, Jalan Penyarir,  
Section U1, Off jalan Glenmarie,  
MY-40150 Shah Alam  
Tel: +60 603 5569 1006  
info@stada.com.my  
www.stada.com.my

## **NO**

**Teijo Norge A.S**  
Husebysletta 21  
Postboks 561  
NO-3412 Lierstranda  
Tel: +47 3222 6565  
firmapost@teijo.no  
www.teijo.no

## **PE**

**Efixo**  
Calle 3 MZ. N LT. 15  
Parque Industrial El Asesor  
Ate, Lima, PE – Perú  
Tel: (00511) 583-8541  
Cel: (0051) 968-140-066  
contacto@efixo.pe  
http://www.efixo.pe

## **PL**

**Bart Sp. z. o.o.**  
ul. Będzińska 41/1  
PL-41-205 Sosnowiec  
Tel: +48 32 256 22 33  
info@bart-vent.pl  
www.bart-vent.pl

## **PT**

**Metec-Mecano Técnica, Lda.**  
Lugar da Cova da Raposa Sete  
Casas  
PT-2670-570 Loures  
Tel: +351 21 797 02 91  
geral@metec.pt  
www.metec.pt

## **RU**

**SovPlym Ltd**  
Revolution Highway, 102-2  
RU-195279, St Petersburg  
Tel: +7-812-33-500-33  
mau@sovplym.spb.ru  
www.sovplym.com

## **SG**

**Blöndal (S) Pte Ltd**  
52 Ubi Ave 3  
Frontier Building  
#03-29  
SG-Singapore 408867  
Tel: +65 6741 7277  
Info@stada.com.my  
www.stada.com.my

## **TR**

**Ventek Mühendislik Ltd**  
Adnan Kahveci Bulvari  
Ünverdi İş merkezi Nr 73  
Dr: 30 Bahçelievler  
TR-Istanbul  
Tel: +90 212 4415596-97  
info@ventek.com.tr  
www.ventek.com.tr

## **UAE**

**Global Enterprises Trading Co**  
Mussafah M14  
AE-Abu Dhabi/Alain  
Tel: +971-2-555 4733  
global@globalentco.com  
www.globalentco.com

## **GEM Industrial Equipment Trading Co**

DIP-1, Greens Community  
AE-Dubai, Mena region  
Tel: +971-4-8840 474  
gemuae@eim.ae

## **UK**

**Dustcontrol UK Ltd.**  
7 Beaufort Court,  
Roebuck Way, Knowlhill  
Milton Keynes MK5 8HL  
England - GB  
Tel: +44 1327 858001  
sales@dustcontrol.co.uk  
www.dustcontrol.co.uk

## **US**

**Dustcontrol Inc.**  
6720 Amsterdam Way  
US-Wilmington NC 28405  
Tel: +1 910-395-1808  
info@dustcontrolusa.com  
www.dustcontrol.us

[www.dustcontrol.com](http://www.dustcontrol.com)